

SIMULATION MODELING OF OLEAGINOUS ROSE HARVESTING IMPLEMENT

SNEZHAN BOZHKOV*; STANISLAV STANCHEV; TSONKA GYORINA

Agricultural Academy, N. Pushkarov Institute of Soil, Science Agrotechnologies and Plant Protection, BG – 1331 Sofia, Bulgaria

Abstract

Bozhkov, S., S. Stanchev and T. Gyorina, 2017. Simulation modeling of oleaginous rose harvesting implement. *Bulg. J. Agric. Sci.*, 23 (5): 873–881

The only one non-mechanized operation in the cultivation of oleaginous rose is picking of the rose blossoms.

In the publication are presented the results of a study on creation of a farm implement for mechanizing the oleaginous rose harvesting. By simulation modeling are determined the types of materials and profiles for the elaboration of basic elements of the newly developed structure. Is assessed the impact on the structural strength, which exert the occupied positions of pickers on the platforms (standing or sitting), the number of rose-pickers on the implement and the approved by BDS and ISO-standards schemes for connecting the implements to the agricultural middle power tractors. It is studied a constructive variant in which the farm implement is without running wheels.

The results of computer modeling are basis for manufacture of experimental model of three-modular rose harvesting implement for checking the structural strength, functional suitability and safety at work with it in real conditions.

Key words: oleaginous rose; harvesting; mechanization; farm implement; simulation modeling; structural strength; factor of safety

Introduction

In accordance with world practice (Lebedev, 1989; Mastinu et al., 2006; Schramm et al., 2010 and others) the creation of objects in the technical area is beginning with computer study of structures through simulation modeling of the performance of product under external impacts, typical for the real conditions of operation. For this purpose, by using appropriate software a simulation model is developed, by which to explore and optimize design decisions. This approach has been applied in the study conducted in the Institute of soil science, agrotechnologies and plant protection (ISSAPP) “Nikola Pushkarov” – Sofia on the creation of a farm implement for mechanizing the blossoms harvesting from the oleaginous rose plantations. The developed technical solution (Bozhkov et al., 2012; Mihov et al., 2014) provides for the rose harvesting

implement to be able to be realized in versions with pneumatic and manual picking of the rose blossom, each one more or less to make it possible to increase the efficiency of rose production and improve the working conditions of rose-pickers. Conceptual design of a farm implement for mechanization of oleaginous rose harvesting is presented in Figure 1.

The three-modular farm implement for mechanization of oleaginous rose harvesting (hereinafter “rose harvesting implement”) (Figure 1) is designed as a semi-mounted portal structure comprising a carrier frame (1), working modules (2), consoles with running wheels (3) and additional equipment to enable its effective use in the production process. To the carrier frame by means of fixing units are fastened the working modules, each of which during operation is located between two adjacent rows of rose bushes. The working modules may be positioned along the length of the carrier

*Corresponding author: bozhkov@mail.bg

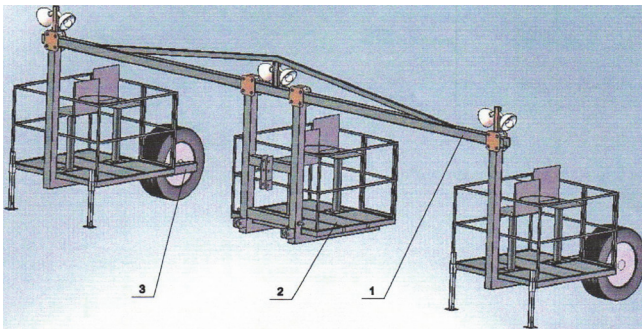

Fig. 1. Conceptual design of three-modular farm implement for oleaginous rose harvesting

frame according to the width of the rows spacing, moved closely to each other (for example during transportation) and disconnected in case of necessity. Every working module consists of L-shaped frame (for the middle module they are two) and a loading platform with protective parapet located on its perimeter. On the platform are formed two working places (front and rear) for simultaneous service on one half of two adjacent rows of rose bushes. Each working place includes a seat for the rose-picker and stand for removable container of collected production, which is located behind the seat of the other working place. At the front part of the middle working module is shaped implement's triangle for connecting the rose harvesting implement to middle power agricultural tractor (Bozhkov et al., 2014). The type and size of the hitch attachments of implement's triangle enable mounting to tractor linkages, designed in accordance with the national BDS-standard (BDS 15648-83) and the international ISO-standard (ISO 730:2009). Each side working module is equipped in its front part with two height-adjustable supports.

The running wheels of three-modular implement are attached via console structures to the lower rear edge of the L-shaped frames of the side modules. The flanged connection of the console structures to the modules allows easy relocation of the running elements when transporting the farm implement on the roads for public use. The implement drawbar is also flange connected. It serves as a connection with the tractor when the rose harvesting implement is in transportation position. The places and items for retrofitting the implement in option for transportation are not depicted in Figure 1.

The rose harvesting implement is completed with light-signaling system for communication between the rose-pickers and tractor driver in the event of unusual situations. For illumination of the processed by the rose-pickers sections of the rows at the start of the working day before sunrise are provided lighting fixtures. It is envisaged that the version of

the farm implement with the pneumatic picking of the rose blossom to be equipped with additional pneumatic picking off system for separation of the blooming flowers from the rose plant and its transportation to the removable container for its storage (Stanchev and Bozhkov, 2016).

The aim of the study is by simulation modeling to determine the parameters and select the materials for production of basic units of a structure that guaranties the strength and ensure safe operation of the farm implement for mechanizing the oleaginous rose harvesting in real conditions.

Materials and Methods

In conducting the study for determination of profiles and type of materials for manufacture of a farm implement for mechanizing the oleaginous rose harvesting is used the "Solid Works" software. Based on the developed conceptual design of rose harvesting implement is created a physical functional-geometrical simulation 3-D model of the structure by which are modeled situations that would be real in the operation of the implement in practice. To facilitate the work of the program and to improve the visualization of the results of the study distinct elements of the structure including the protective parapet, the elements of pneumatic picking off system, lighting system and light-signaling system, the stands and containers for the collected product, the seats, the supports of the side modules, the rims and wheel tires of the running elements are not presented clearly in the simulation model. Their presence in the physical model (the farm implement) was reflected in the simulation model with their real masses, applied to the places of their location.

The type of profiles for the manufacture of the basic units of the structure of the rose harvesting implement was initially selected by the authors, on the basis of their experience in designing machinery for agriculture and available materials on the market. For the implement's carrier part incorporating the carrier frame, L-shaped frames and consoles for the running wheels, this is a hollow square profile with dimensions 100x100x6 mm, and for the loading platforms of the working modules – hollow square profile with dimensions of 60x40x3 mm and riffled metal sheets with a thickness of 3 mm. In the process of optimizing the structure of the rose harvesting implement are explored options with profile's wall thickness of the carrier part 5, 4 and 3 mm and for the loading platform 2 mm. It was modeled an option for manufacture of the carrier part of the structure from hollow square profile with dimensions of 80x80 mm and for the loading platform from rectangular hollow profile with dimensions of 40x30x3 mm. Some studies have been performed with different thicknesses of the profile with dimensions of 80x80

mm.

On the simulation model are applied the supporting reactions at the implement's hitch-point triangle for connection to the rear mounted three-point linkage of the tractor, the reactions in the hubs of the running wheels and external to the structure forces due to the traction force of the tractor and the impact of the weight of rose-pickers and collected by them production (Figure 2).

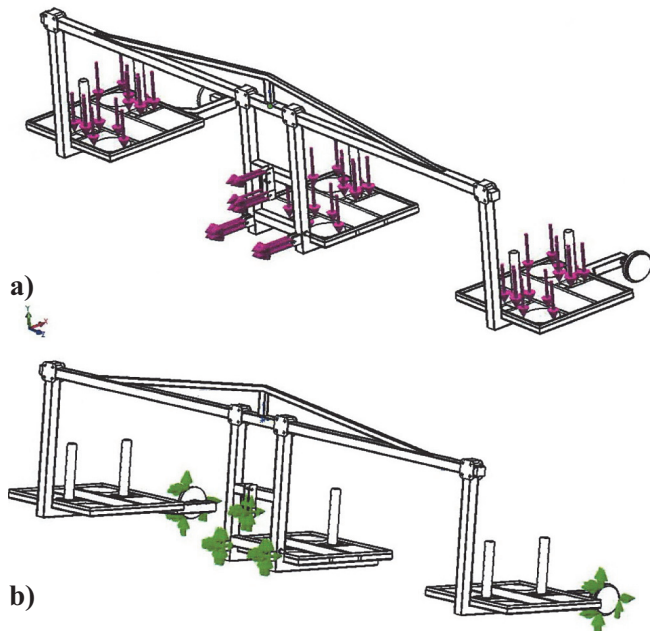

Fig. 2. Simulation model of three-modular rose harvesting implement with (a) the applied forces caused by the traction force of the tractor, from the action of the weight of pickers and collected production and (b) the supporting reactions at the hitch-point triangle and the running wheels

For reference have been adopted:

- the scheme for connection of the farm implement to the tractor -TNU-2 var.B (BDS 15648-83) used in the majority of middle power tractors operated in Bulgarian agriculture;
- the position of the rose-pickers on the platform – sitting.

The value of the applied external forces are selected in a way to be close to the maximum (drawbar pull – 2 kN, weight of rose-picker – 80 kg and a mass of the gathered by him rose blossoms – 20 kg).

Comprehensive evaluation of the structural strength of the rose harvesting implement was carried out with the aid of

the indicator “factor of safety”¹ (Shigley and Mischke, 1986), determined by the program „Solid Works“. In the calculation, the value of the indicator „yield strength“ was accepted $\sigma_s = 248.17$ MPa, which is close to the maximum for the material of the steel profiles of which the essential elements of the farm implement, will be made. The values for the factor of safety are calculated also in the usage of steel profiles, which have a lower strength (Steel grade S235 JR), but are widely used in engineering practice and more easily accessible on the market.

For precise evaluation of the structural strength were analyzed the data for the emerging in it stresses and deformations. While the stresses are determined in each of the constituent elements of the structure, deformations are evaluated complexly via the parameter “maximum displacement of element of the structure from its position without load”. The determined by the program “Solid Works” parameter is the resultant expression of the elastic changes occurring in the structure under the influence of applied external forces.

Were studied the operational situations in which the three-modular rose harvesting implement is with different schemes for connecting to the agricultural tractor, with different occupied by pickers position on the loading platform (standing / sitting), with different number of pickers on the loading platforms and the design option at which the farm implement is without the running wheels. It was observed the impact caused by the type of profiles on the following parameters and indicators: the constructive mass of the farm implement; the stresses in structures and places of occurrence of their limit values; deformations in the structure, including the maximum value and place of occurrence of displacement of its element from its original position (i.e. “without load”); the location of the center of gravity; the factor of safety. The beginning of the coordinate system in respect of which is determined the location of the monitored parameters and indicators, is situated in the longitudinal plane of symmetry of the farm implement on the axis of the main (carrier) beam of the carrier frame (Figure 2).

Results and Discussion

The values of monitored parameters and indicators of the three-modular rose harvesting implement, of which the car-

¹ Factor of safety (FOS) – indicator that shows the ability of the structure to withstand loads applied to it, higher than calculated. It is calculated as the ratio between maximum stress (σ_{max}), which occurs in the structure in result of the action of external loads and yield strength of the material (σ_s), from which it is made. In engineering practice has been accepted its value to be between 2,4...4.

rier frame, L-shaped frames and console structures for the running wheels are made of hollow square profile with external dimensions of 100x100 mm and thicknesses from 3 to 6 mm, are presented in Table 1.

“Belarus”, UMZ-6L/6M and TK-80 “Bolgar”² – the most widespread middle power tractors in Bulgarian agriculture. Under permissible for continuous operation lifting capacity of the above mentioned tractors is also the part of the

Table 1
Results of simulation modeling of three-modular rose harvesting implement with carrier part of hollow square profile with external dimensions of 100x100 mm

Parameter / Indicator	Thickness of the walls of profile, mm			
	3	4	5	6
Constructive mass, kg	639.1	698.0	755.4	812.1
Center of gravity, mm with coordinates				
X	603	576	553	533
Y	-1068	-1043	-1022	-1005
Z	0	0	0	0
Factor of safety (FOS)				
at $\sigma_s = 248.17$ MPa	1.930	3.196	3.610	4.179
at $\sigma_s = 235$ MPa	1.828	3.027	3.418	3.957
Maximum stress σ_{max} , MPa	128.572	77.642	68.752	59.382
place of occurrence:	consoles of running wheels		axis of running wheel	
Maximum displacement of element of the structure from position “without load”, mm	3.9	3.5	3.1	2.9
place of occurrence:	external front edge of the side loading platforms			
Difference in the masses of the implements, %	21.3	14.0	7.0	base

Table 2
Mass parameters of three-modular rose harvesting implement

Type of profile of the carrier part of the structure	Operating mass of the implement		Operating mass in the axis of lower hitch points of the tractor linkage, kg
	Value, kg	Longitudinal coordinate of the center of gravity, mm	
100x100x6	1412.0	583	904.6
100x100x5	1355.4	596	859.4
100x100x4	1298.0	610	813.8
100x100x3	1239.1	626	767.3

With the data for the constructive mass and the coordinates of the center of gravity of the farm implement for each of the reviewed options are calculated values of its operating mass and the portion of the operating mass assumed by tractor linkage in working position of the implement (Table 2).

Analysis of the data from Table 1 and Table 2 shows that regardless of the thickness of the walls of the profile, used for elaboration of the carrier part, the constructive mass of the rose harvesting implement is far below the maximum lifting capacity of the three-point linkages, which are mounted even on older tractor models such as MTZ-80

operating mass of the farm implement, which is assumed by the linkage (the recalculated value of rated lifting force at the hitch points of the linkage lower links is 10.7 kN / 1090 kg). The findings give grounds to assert that each of the modeled variants of the structure can be connected to

² According the technical data (Tractor Bolgar TK-80 - Instruction Manual) the rated lifting force of the linkage of the wheeled tractor TK-80 “Bolgar” is 7,85 kN / 800 kg at a distance of 1500 mm from the axis of the running wheels of the rear axle. The maximum lifting force at the hitch points of the lower links of the linkage is 2000 kg. The same are the values of the lifting force of the linkages of tractors MTZ-80 „Belarus“ and UMZ-6L/6M

each middle power tractor operating in the world agriculture. Besides trouble-free operation in the lowered position is also guaranteed and sustainable control of tractor/implement combination for rose harvesting in full raised farm implement for realization of maneuvers and its transportation in close distances in the regions of its operation and storage.

Despite the significant dimensions of the rose harvesting implement (prepared for raw spacing of 3.2 m its length, width and height respectively are 2.4 m x 7.65 m x 2.25 m), deformations in structure are insignificant. This finding is confirmed by the calculated values for the parameter “maximum displacement of the structural element from its position without load”. The obtained results are testimonial to the strength of the structure and guarantee for preserving the stability of rose-pickers on the implement during operation.

The analysis of data from Table 1 shows that it is inappropriate in the manufacture of the three-modular implement to be used the initially selected hollow square profile with dimensions 100x100x6. With the said thickness of the profile the rose harvesting implement has a factor of safety that exceeds the recommended upper limit for similar types of structures, and is with unduly high weight. Despite the fact that it provides the lowest material consumption, the use of profile with dimensions 100x100x3 for the manufacture of the carrier part of the three-modular implement is unacceptable. The resulting stresses are with values that make risky the use of the farm implement in the practice.

From the results of Table 1 it can be assumed that suitable for production of carrier part of the three-modular rose harvesting implement are the hollow square profile with dimensions 100x100x5, as well as with dimensions of 100x100x4. For both cases the calculated lowest value for the factor of

safety of the structure is within the recommended for engineering practice range, even if the metal profiles are from the widespread but with lower-strength steel type S235JR (Standard BDS EN 19219-2:2006 with yield strength $\sigma_s = 235$). This is the reason, the further research to refine the decision on the admissibility of using two profiles be carried out only with them.

In Table 3 are presented results from modeled structures with carrier part from profiles 100x100x4 or 100x100x5 and loading platforms made of profiles thinner than the initially selected wall thickness. Their analysis shows that the increase of deformations in the structure is negligible. There is a reduction of the constructive mass of the farm implement and lowering of the factor of safety does not threaten the structural strength, even if made of materials with lower strength.

In Table 4 are presented the values of parameters and indicators obtained as a result of simulation modeling of structure of the rose harvesting implement, in which the carrier part is made of a hollow square profile with dimensions of 80x80 mm and wall thickness of 3, 4, 5 or 6 mm, and the loading platform from hollow rectangular profile with dimensions of 40x30x3 mm. The difference in masses is evaluated with respect to the mass of the implement elaborated with initially selected profiles for the carrier part and loading platforms.

The results of Table 4 show that the factor of safety whose value is above the accepted as minimum in engineering practice for both type of steel, provides the profile with dimensions 80x80x6. Its usage instead of the initially selected 100x100x6 would allow reducing the material consumption of the rose harvesting implement with about one third, but the decision should be taken after precise research on

Table 3
Results of simulation modeling of three-modular rose harvesting implement with loading platforms of hollow rectangular profile 60x40 with different wall thicknesses

Parameter / Indicator	Value, description			
Profile for the carrier part	100x100x4		100x100x5	
Profile for the loading platform	60x40x3	60x40x2	60x40x3	60x40x2
Constructive mass, kg	698.0	668.1	755.4	725.2
Factor of safety (FOS)				
at $\sigma_s = 248.17$ MPa	3.196	2.894	3.610	3.404
at $\sigma_s = 235$ MPa	3.027	2.740	3.418	3.224
Place of occurrence of σ_{\max}	consoles of running wheels			
Maximum displacement of element of the structure from position “without load”, mm	3.10	3.53	3.08	3.11
place of occurrence:	external front edge of the side loading platforms			

Table 4
Results from simulation modeling of three-modular rose harvesting implement with carrier part from hollow square profile with external dimensions of 80x80 mm and a loading platforms from hollow rectangular profile with dimensions of 40x30x3 mm

Parameter / Indicator	Thickness of the walls of profile 80x80, mm			
	3	4	5	6
Constructive mass, kg	410.0	457.3	502.8	547.4
Factor of safety (FOS)				
at $\sigma_s = 248.17$ MPa	0.833	1.893	2.517	3.080
at $\sigma_s = 235$ MPa	0.789	1.792	2.383	2.916
Maximum stress σ_{max} , MPa	297.70	131.12	98.60	80.58
place of occurrence:	consoles of running wheels			
Maximum displacement of element of the structure from position "without load", mm	6.7	5.1	4.2	3.7
place of occurrence:	external front edge of the side loading platforms			
Difference in the masses from initially selected variant, %	49.5	43.7	38.1	32.6

the increase of the stresses and deformations in structures in situations typical for the real operating conditions.

Absolutely not suitable for the manufacture of the carrier part of the farm implement are the profiles with a thickness of 3 and 4 mm. The use of profile 80x80x5, even made from materials with high strength qualities, is risky in terms of structural strength and safety for operating the implement. For optimization of the implement parameters can be checked also variants with hollow square profiles with dimensions between the examined.

To assess the impact of the operational factors on the structural strength, are modeled variants that would have been common for usage of the rose harvesting implement in the practice. In Table 5 are presented the results of simulation modeling for determination the impact of the scheme for connection of rose harvesting implement to the linkage of the tractor. For two versions of the carrier part of the structure were studied the four approved by BDS and ISO standards schemes for connection of implement to agricultural middle power tractors.

It was ascertained that the scheme for connection of implement to the tractor does not affect the place of occurrence of maximum stress in the structure. The minimum dif-

ferences in factors of safety give grounds to state that the rose harvesting implement can seamlessly be attached to all established by standards linkages of the operated in world agriculture middle power tractors and this will not degrade the structural strength.

In Table 6 are presented the results of simulation modeling of rose harvesting implement for determination the influence of the position occupied by the rose-pickers during work. Were studied the implement's structures with carrier part made of profiles 100x100x4 or 100x100x5, with sitting and standing positions of rose-pickers on the platform.

It was established that the position occupied by pickers almost does not affect the absolute value of the resultant of the emerging deformations in structures and that ensure the sustainability of the placed on the loading platforms persons during the execution of technological operation. Significant, however, is the impact of the studied operational factor on the values of stresses occurring in the structure. The calculated value for the evaluating the structural strength factor of safety for the variant of the implement with carrier part made of profile 100x100x4 is close to the minimum, accepted in the engineering practice. This assumes conducting a study of the specified variant together with others typical for the

Table 5
Factors of safety (FOS) at different schemes for connection of three-modular rose harvesting implement to the tractor (at $\sigma_s = 248.17$ MPa)

Dimensions of the profile for the manufacture of the carrier part of the rose harvesting implement	Type of tractor linkage			
	TNU-2 Var. A under BDS	TNU-2 Var. B under BDS	cat.2 under ISO	cat.2N under ISO
100x100x4	3.194	3.196	3.193	3.182
100x100x5	3.606	3.610	3.606	3.607

Table 6
Results of simulation modeling of three-modular rose harvesting implement at different positions occupied by the pickers during the work

Parameter / Indicator	Type and dimensions of the profile, mm			
	Hollow square profile with dimensions 100x100x4		Hollow square profile with dimensions 100x100x5	
Position of the rose-pickers	sitting	standing	sitting	standing
Maximum displacement of element of the structure from position "without load", mm	3.5	3.6	3.1	3.2
place of occurrence:	external front edge of the side loading platforms			
Factor of safety, FOS	3.196	2.550	3.610	3.416
Place of occurrence of σ_{\max}	consoles of running wheels			

practice factors, in order to verify the possibility of further reducing the value of the coefficient below the permissible minimum.

During the mechanized oleaginous rose harvesting fully real will be the situations of motion of tractor/implement combination for rose picking with uneven distribution of pickers on the loading platforms of farm implement. One of the endmost pickers would be absent when the tractor/implement combination runs in the first and last row spacing of rose plantation and three pickers when the tractor is moving outside the rose plantation and one of the side modules of the implement is in the last row spacing. It was modeled a situation in which on the farm implement remained only three pickers who collect rose blossoms in standing position. Results of the computerized study of the variants of rose harvesting implement with carrier part of the profiles 100x100x4 and 100x100x5 are presented in Table 7.

The analysis of the results in Table 7 shows that from the studied variants in this appearance for safe operation in the conditions of rose production is admissible only the imple-

ment with a carrier part made of profile 100x100x5. In the version with a carrier part made of profile 100x100x4 apart from the registered bigger and asymmetrical deformations in structure, there are concentrations of stresses that lead to a decline in the value of the factor of safety, significantly below the accepted minimum limit. It can be assumed that the strengthening in appropriate way the places of the units where the maximum stresses are detected will lead to solving the problem with the strength of the structure. Another possibility is the fabrication of consoles of the running wheels by profile with bigger thickness, although this will increase the construction mass of the farm implement.

In Table 8 are presented the results of modeled structures, whose elements of the carrier part are made of profiles with dimensions of 100x100 and various wall thicknesses.

The common for variant 2, variant 3 and variant 4 is their lower material consumption compared to the accepted as a base of reference – variant 1. With a guaranteed good structural strength is variant number 2. It also can be expected that the lightest of all – the variant under number 4 will fully

Table 7
Results of simulation modeling of three-modular rose harvesting implement with different number of pickers on it

Parameter / Indicator	Type and dimensions of the profile, mm			
	Hollow square profile with dimensions of 100x100x4		Hollow square profile with dimensions of 100x100x5	
Position of the rose-pickers	standing	standing	standing	standing
Number of pickers on the implement	6	3	6	3
Maximum displacement of element of the structure from position "without load", mm	3.6	5.3	3.2	4.5
place of occurrence:	external front edge of the side loading platforms	upper left or right edge of the carrier beam	external front edge of the side loading platforms	upper left or right edge of the carrier beam
Factor of safety (FOS)	2.550	1.858	3.416	2.690
Place of occurrence of σ_{\max}	consoles of running wheels			

Table 8

Results of simulation modeling of three-modular rose harvesting implement with carrier part of hollow square profile with external dimensions of 100x100 mm and various wall thicknesses

Parameter / Indicator	Thickness of the profile with external dimensions of 100x100, mm			
	Car. beam-5mm; L-frame-5 mm; Con- soles-5 mm	Cer. beam-5 mm; L-frame-4 mm; Con- soles-5 mm	Cer. beam-5mm; L-frame-4 mm; Con- soles-4 mm	Cer.beam-4mm; L-frame-4 mm; Con- soles-5 mm
Number of variant	1	2	3	4
Constructive mass, kg	755.4	722.2	718.1	703.2
Factor of safety (FOS)				
at $\sigma_s = 248,17$ MPa	3.610	3.555	2.732	3.313
at $\sigma_s = 235$ MPa	3.418	3.367	2.587	3.138
Place of occurrence of σ_{max}		consoles of running wheels		
Maximum displacement of element of the structure from position "without load", mm	3.08	3.10	3.27	3.30
place of occurrence:	external front edge of the side loading platforms			

satisfy the requirements, although the calculated resultant of the emerging in the structure deformations is greatest. Confirmation or rejection of the made assumptions will give the experimental testing of the rose harvesting implement in real conditions.

The computer modeling of a variant in which the three-modular rose harvesting implement is without its own running wheels, rejected the possibility of its existence as such. Despite the fact that design difference reduces the total mass of the implement by more than 11% in both studied variants of the rose harvesting implement there is significant deterioration of the factor of safety, as well as the occurrence of deformations that cause increasing over 11 times displacements of elements of the structure from their position without load (Table 9). In using the rose harvesting implement in practice, due to unevenness of the supporting surface, the change in the position and number of rose-pickers and other

operational factors completely real is the emergence of significant fluctuations that will disrupt the stability and drivability of the tractor/implement combination and threaten the safety of working on the implement pickers.

The positive result from this part of the study is that are proved the potentials of the technical solution that ensure the preservation of the structural strength in maneuvering or transportation of the three-modular rose harvesting implement at close distances in raised position.

Simulation modeling has helped not only be selected types of profiles and materials for the manufacture of basic elements of the structure, but also optimized design parameters and improved important operational indicators of the three-modular rose harvesting implement. The identified as a result of the modeling concentrations of stresses and increased deformations in the structure of the implement allowed taking adequate measures to prevent possible negative

Table 9

Results of the simulation modeling of three-modular rose harvesting implement with and without running wheels (position of picker – seated)

Type and dimensions of the profile, mm	Hollow square profile with dimensions 100x100x4		Hollow square profile with dimensions 100x100x5	
Presence of consoles with running wheels	Yes	No	Yes	No
Constructive mass, kg	698.0	603.6	755.4	656.4
Maximum displacement of element of the structure from position "without load", mm	3.5	40.0	3.1	34.1
place of occurrence:	front external edge of the side loading platforms	rear external edge of the side loading platforms	front external edge of the side loading platforms	rear external edge of the side loading platforms
Factor of safety, (FOS)	3.196	2.263	3.610	2.721
Place of occurrence of σ_{max}	consoles of running wheels	connection between the tie-back profiles of carrier frame	consoles of running wheels	connection between the tie-back profiles of carrier frame

consequences. The technical solutions are developed that ensure the required strength of the structure and safe operation of the three-modular farm implement in practice.

The results of simulation modeling are the basis for the development of experimental model with which to conduct operational tests for confirmation of the structural strength, functional suitability and safety at work in real conditions of the three-modular rose harvesting implement.

Conclusions

Based on the developed conceptual design for technical solution was created a functional physical-geometrical simulation 3-D model of three-modular farm implement for mechanizing the blossoms harvesting from oleaginous rose plantations.

The computerized study found that the scheme for connection of the rose harvesting implement to the linkage of agricultural tractor had only a negligible impact on the factor of safety by which is evaluating comprehensive the structural strength. The operational factor "position of the rose-pickers (standing / sitting) on the loading platforms" almost does not affect the absolute value of the resultant of the emerging deformations in the structure. More noticeable is its impact on the size of emerging stresses in the structure. As significant can be characterized the influence of the operational factor "reduced number and unevenly distributed pickers on platforms of the implement". In some of the studied variants except the registered higher in volume and asymmetrical in occurrence deformations in the structure, there are concentrations of stresses that lead to a decline in the value of the factor of safety, significantly below the accepted minimal limit.

The computer modeling of a variant in which the three-modular rose harvesting implement is without running wheels, rejected the possibility of its existence as such. Despite the fact that the design difference reduces the constructive mass of the farm implement, along with the deterioration of the factor of safety, there are significant deformations, which will disrupt the stability of the located on the load platforms rose-pickers and endanger their safety when the farm implement operates in field conditions.

The conducted simulation modeling of rose harvesting im-

plement gives reason to conclude that the strength of the structure is fully guaranteed if its carrier part is made of hollow square profile with dimensions 100x100x5, and loading platforms of profile 60x40x3. Without unnecessary risk the profile thickness can be reduced to 4 mm for all elements of carrier part, with the exception of consoles of the running wheels.

References

- BDS 15648-83**, 1983. Agricultural tractors and machinery. Mounted system. Three-point linkage device. Joining dimensions (Bb).
- Bozhkov, S., E. Badrikov and S. Stanchev**, 2014. Universal hitch-point triangle for agricultural implement. Proceedings of the Technical and Scientific Conference ECO Varna, 15 – 17 May 2014, Varna, Bulgaria, pp. 248-255 (Bg).
- Bozhkov, S., E. Badrikov, M. Mihov and O. Bozhkova**, 2012. Substantiation of parameters of the machine for harvest mechanization of rose petals. Proceedings of the Technical and Scientific Conference ECO Varna, 10 – 12 May 2012, Varna, Bulgaria, pp.61-71 (Bg).
- ISO 730:2009**, 2009. Agricultural wheeled tractors-Rear-mounted three-point linkage – Categories 1, 1N, 2, 2N, 3, 3N, 4 and 4N.
- Lebedev, A.**, 1989. Modeling in Scientific and Technical Researches, *Radio i Svyazy*, Moscow, p. 224 (Ru).
- Mastinu, G., M. Gobbi and C. Miano**, 2006. Optimal Design of Complex Mechanical Systems, *Springer-Verlag Berlin Heidelberg*, p. 392.
- Mihov, M., S. Bozhkov, E. Badrikov and S. Stanchev**, 2014. Implement for mechanization of oleaginous rose harvesting, Certificate for utility model №1855/01.04.2014, Patent Office of the Republic of Bulgaria (Bg).
- Schramm, D., M. Hitler and R. Bardini**, 2010. Modellbildung und Simulation der Dynamik von Kraftfahrzeugen, *Springer-Verlag Berlin Heidelberg*, p. 477.
- Shigley, J. and Mischke**, 1986. Standard Handbook of Machine Design, *McGraw-Hill*. pp. 2-15.
- Stanchev, S. and S. Bozhkov**, 2016. Determination of the parameters of a system for pneumatic picking of the flowers from the oleaginous rose plantations. In: Technics and Technologies in Mechanical, Agriculture and Transport, Proceedings of the International Conference on Technics, Technologies and Education ICTTE 2016, 17-18 November 2016, Yambol, Bulgaria, pp. 7-19 (Bg).
- Tractor Bolgar TK-80**. Instruction Manual, *Agrotehnika EAD*, Karlovo, p. 174 (Bg).

Received March, 24, 2017; accepted for printing September, 12, 2017